



През 2008 г. отворихме най-новия завод в България за PVC профили за прозорци и врати „Otto Richter“. Нашата концепция е да предложим достъпен, високотехнологичен продукт, основан на традициите в производството на PVC профили и модерни технологии.

Заводът стратегически е изграден в гр. Силистра. Традициите в областта на екструдирането и наличието на висококвалифициран и обучен персонал, достъпът до пазарите в България, Румъния, Молдова и Украйна предопределиха нашето решение.

Производството обезпечихме с последно поколение машини и оборудване на водещи производители. Всички процеси по екструдирането се извършват с екструдери на световния лидер австрийската фирма Cincinnati Extrusion.

Използването на качествени суровини и материали, както и подобрена формула за сместа придават на нашите профили изключителна белизота, блясък и пластичност.

При разработването на продуктите сме се водили от идеята за вариативност - да дадем възможност за избор при изработката на вратите и прозорците. Произвеждат се най-търсените 3, 4 и 5 камерни профили с ширина 60 мм и 70 мм, които задоволяват всички изисквания на пазара. Съобразявайки се с особеностите на различните пазари предлагаме 4 камерната система във варианти с малка и голяма каса. Предлагаме и PVC система от профили за плъзгащи врати.

Нашите профили се предлагат в два варианта - с монтирано TPV уплътнение (сив или черен цвят по избор), както и без уплътнение с възможност за полагане на EPDM уплътнител.

Произвеждат се 3 вида стъклодържачи - за единично стъкло, за двоен и троен стъклопакет. Стъклодържачите са екструдирани заедно с уплътнителя (който също може да бъде сив или черен). Цветните профили се ламинират в най-търсените разцветки - златен дъб и махагон.

Заводът разполага със собствена лаборатория за изпитване на профилите.

In 2008, we put into operation the newest in Bulgaria plant profiles designed for doors and windows 'Otto Richter'. We the concept of offering affordable high-tech products based tradition in PVC profiles and advanced technology.

The plant is strategically located in Silistra. The city's tradition sion technology and the availability of highly qualified per proximity to markets in Bulgaria, Rumania, Moldova and th have played a determining role in making our decision.

For our production process we have provided latest gener machines and equipment from leading manufacturers. All processes are performed with extruders manufactured by leader the Austrian company Cincinnati Extrusion.

The input of high quality materials, along with the improv mula ensure the special feature of our profiles exceptional brilliance and plasticity.

In developing our products, our leading principle was the variability - to provide various options for manufacturing d windows. Our production includes the highly demanded 3, chamber profiles of 60 mm and 70 mm wide which conform market requirements. With consideration of various market we offer the 4-chamber system in options with a small or la profile. We also offer a PVC system of profiles for sliding do Our profiles are marketed in to variations with fixed TPV g or black options), and without gasket with possibility for fix gasket.

Our production includes 3 types of glazing beads which ar together with the gasket (which also can be grey or bla The coloured profiles are laminated with the most frequent ed colours golden oak and mahogany.

The plant has its own laboratory for profile testing.



Otto Richter

BG 631

BG 632

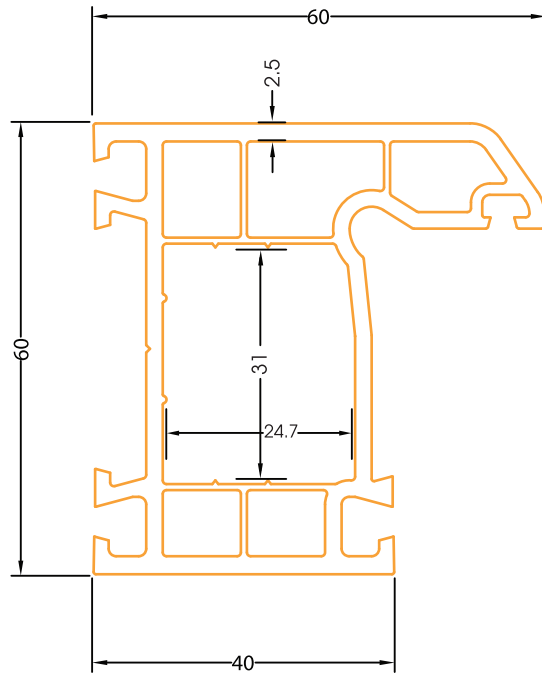

Каса
L Frame profile / Рама
оконная

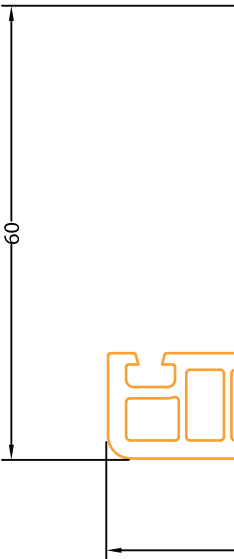
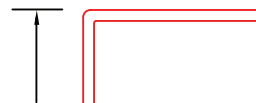

Z s



Otto Richter

BG 633

BG 634

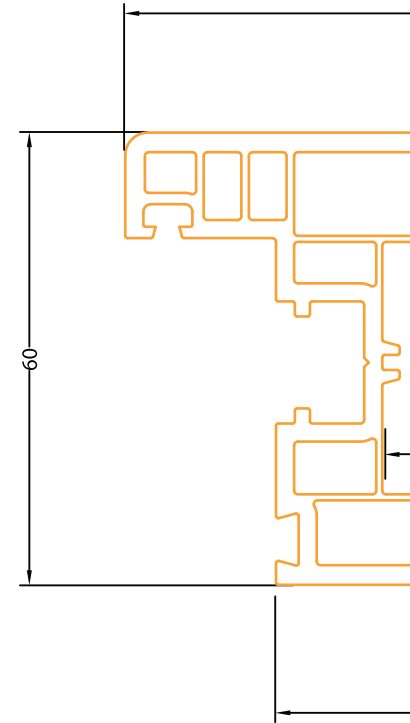
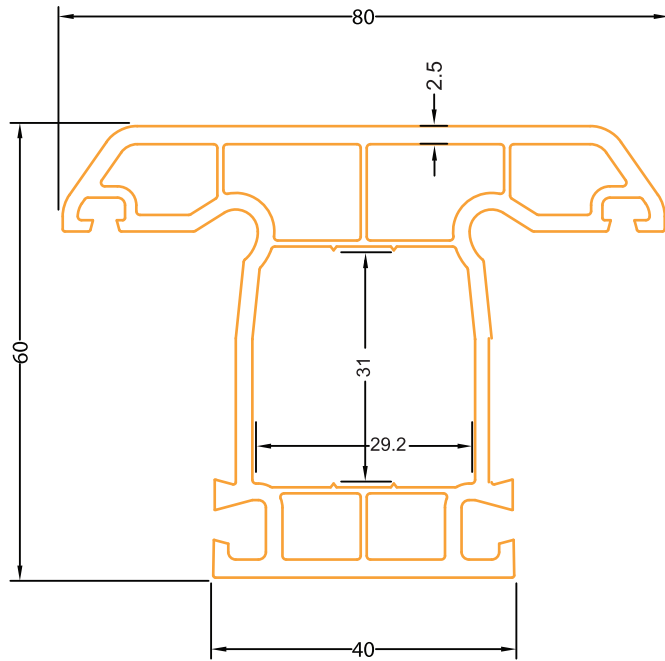

Кемпфер

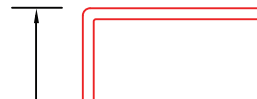



Otto Richter

BG 635

BG 641

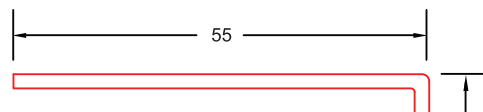
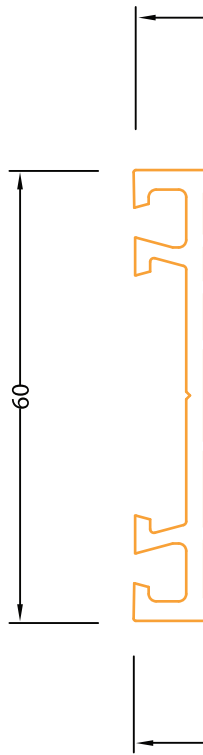
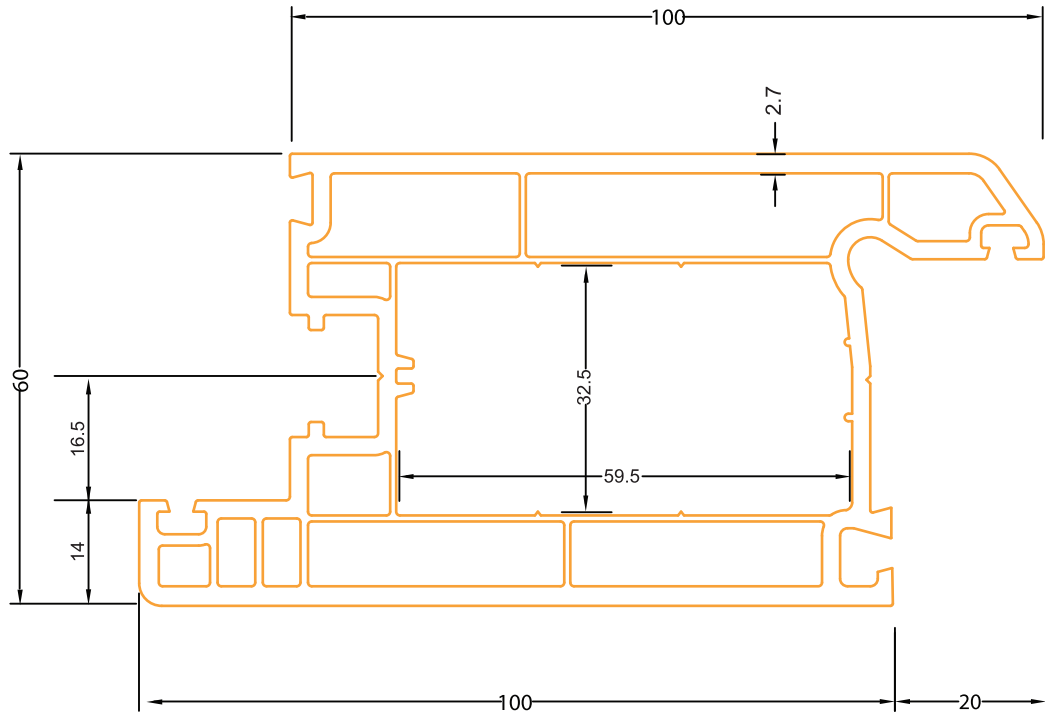



Otto Richter

BG 642

BG 643

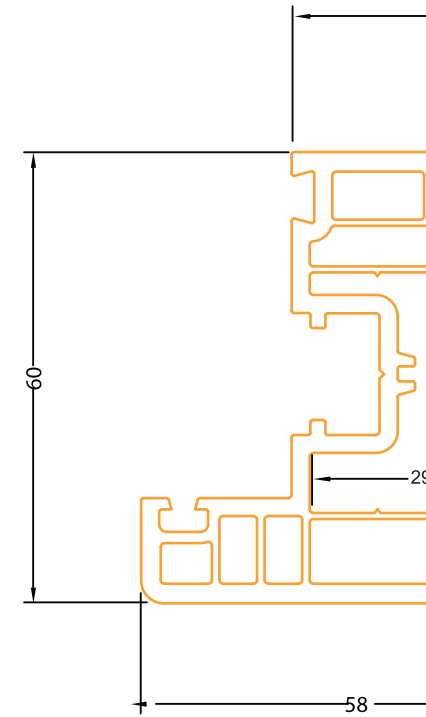
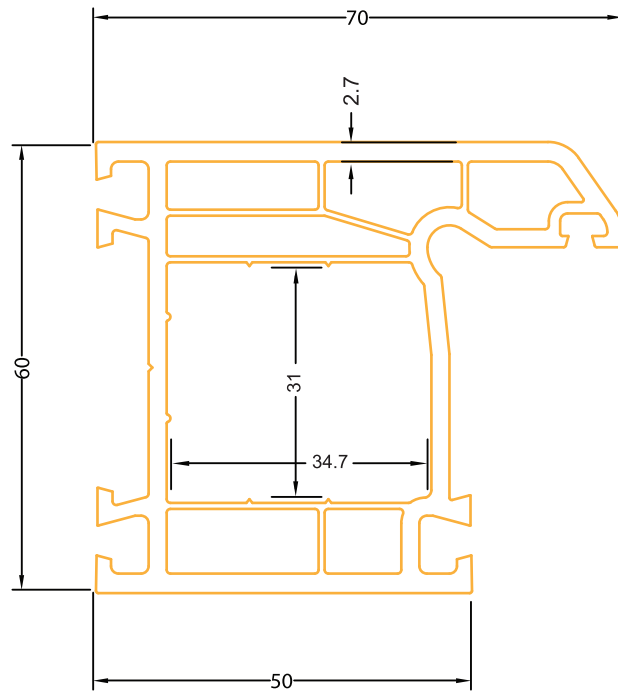

Голяма каса
Super I. Frame profile / Супер Рама оклуца

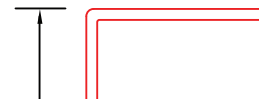



Otto Richter

BG 644

BG 605

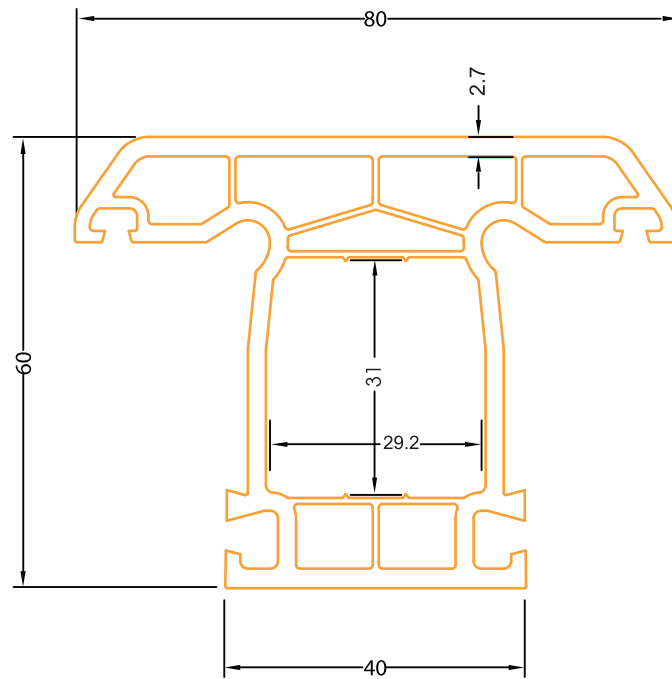

Кемпфер
T Million profile / Импост

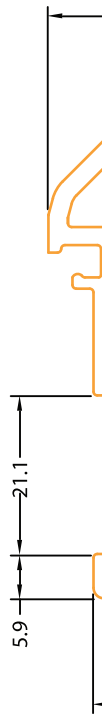
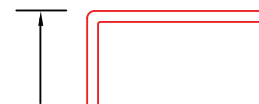

False Million



Otto Richter

BG 651

BG 652

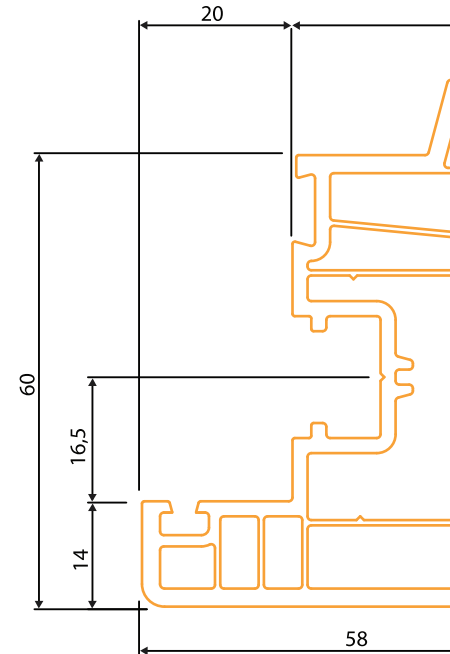
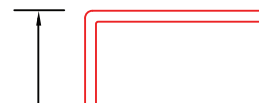
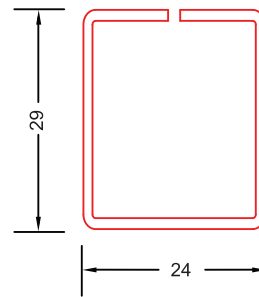
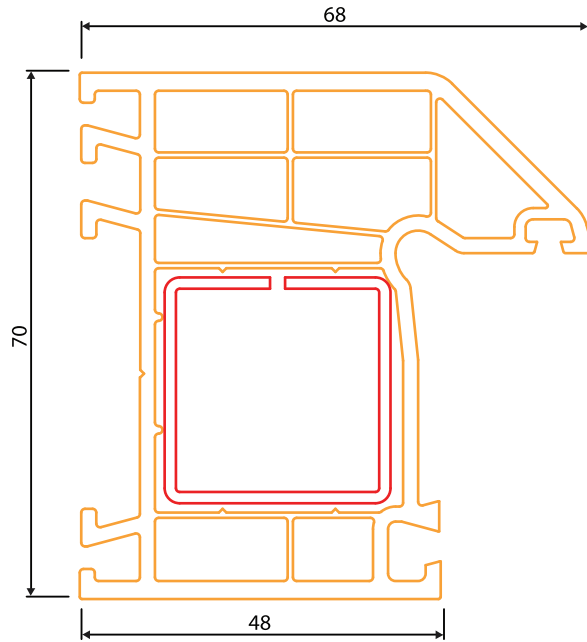



Otto Richter

BG 653

BG 601,602,603

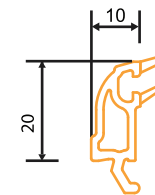
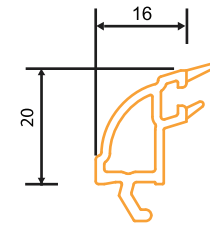
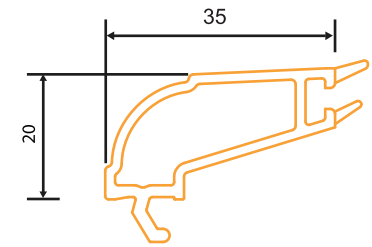
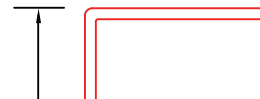
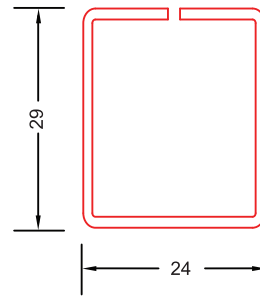
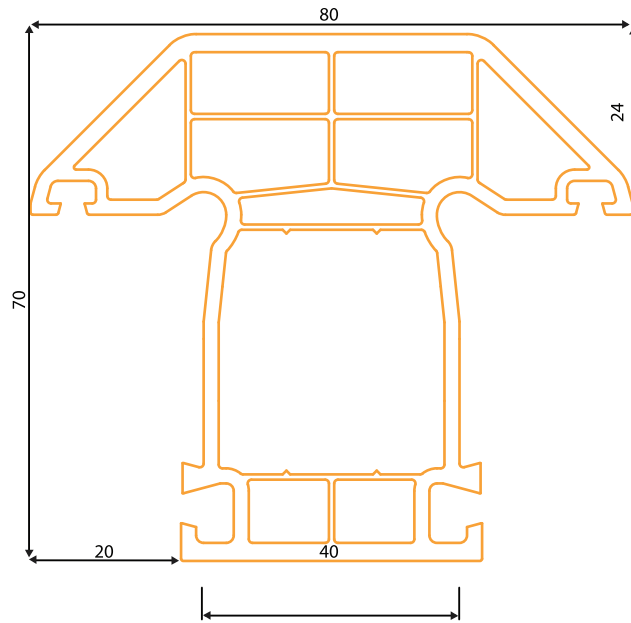

Ст
Single

Sing

Стък
Triple

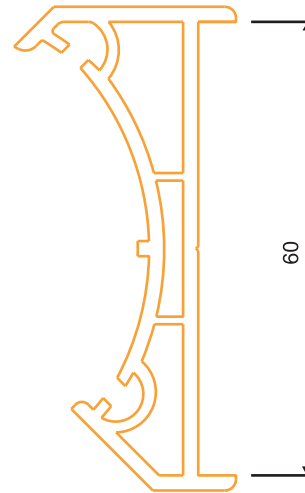
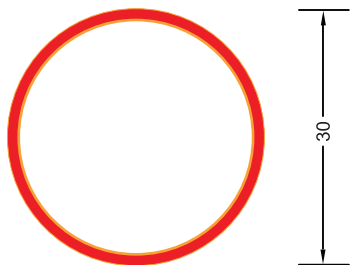
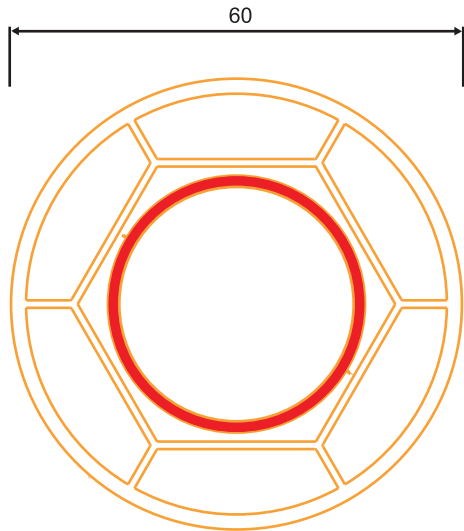



PRO 036 PRO 030

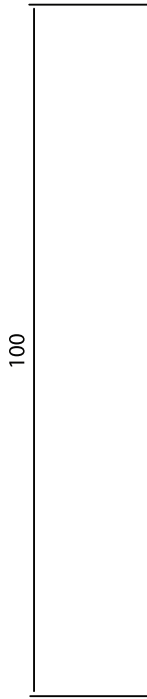
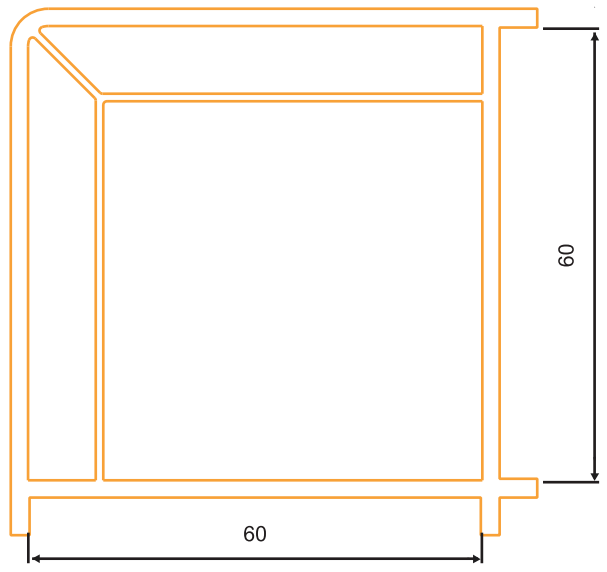



Otto Richter

PRO 037

PRO 039

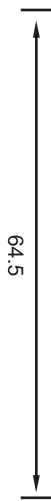
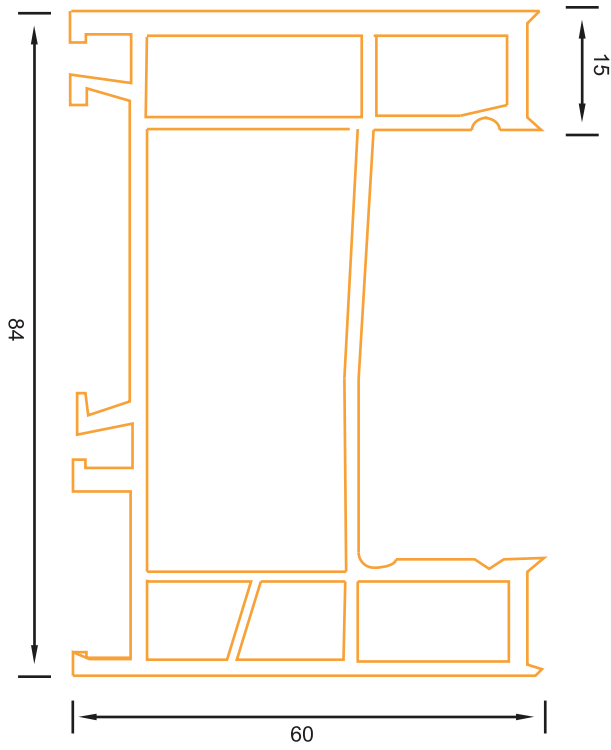

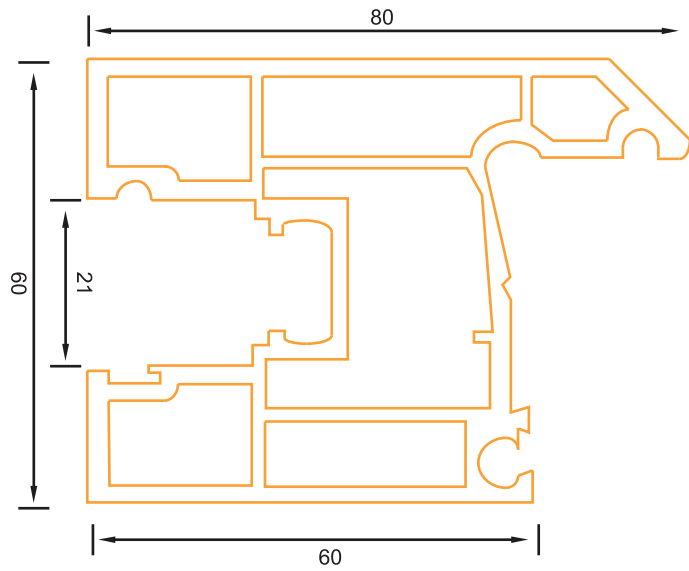



Otto Richter

BG 63

BG 63

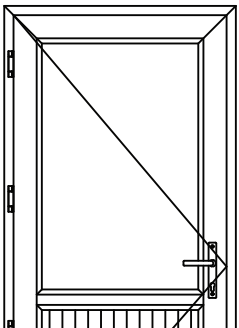
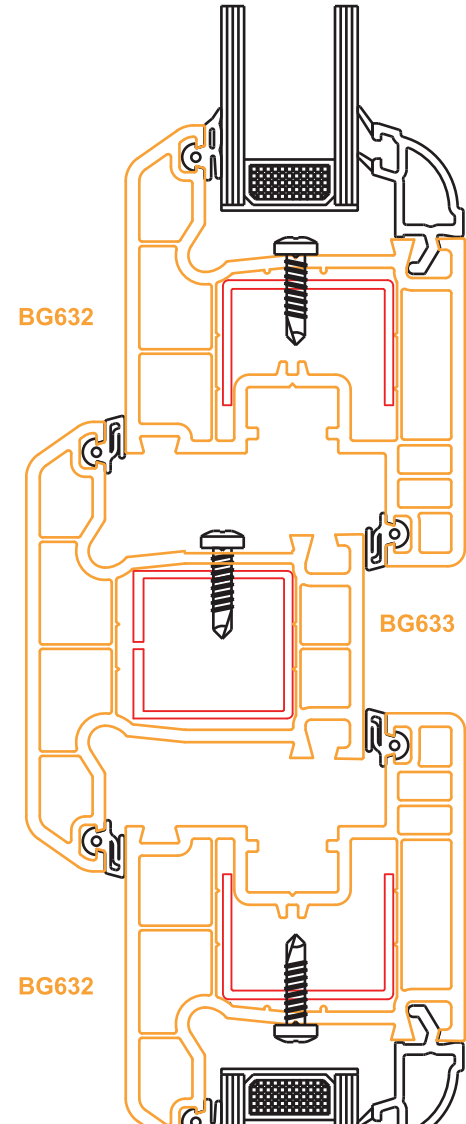
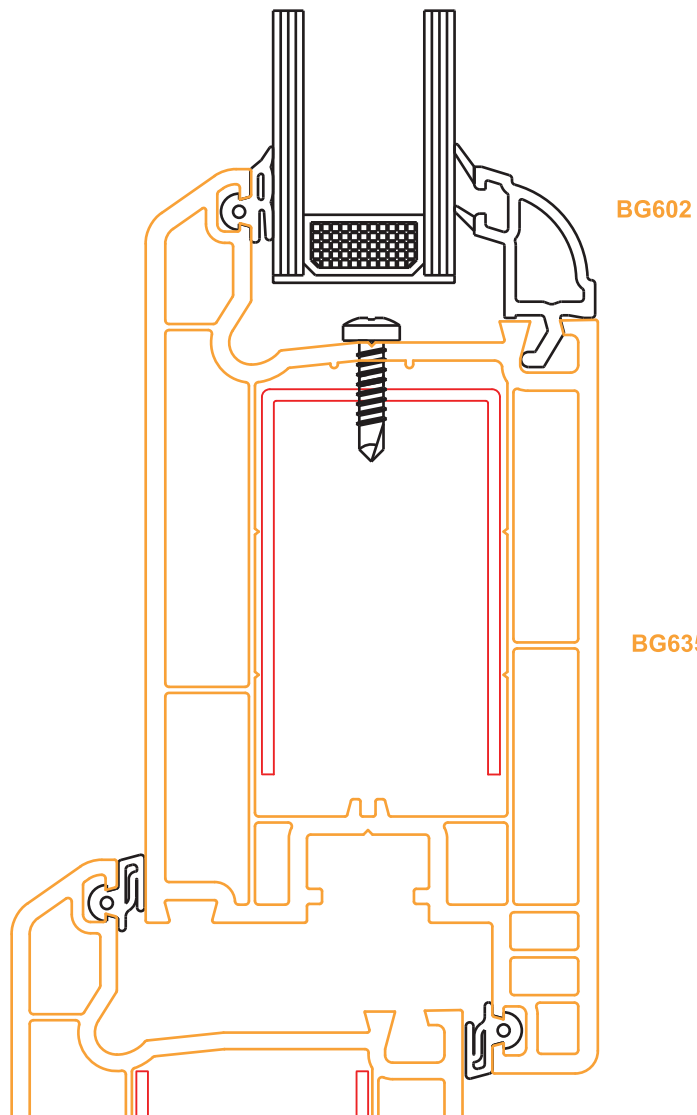

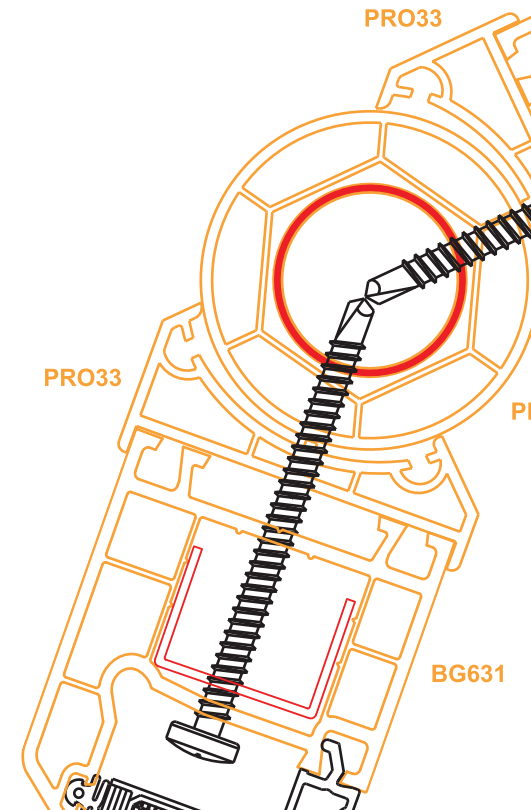
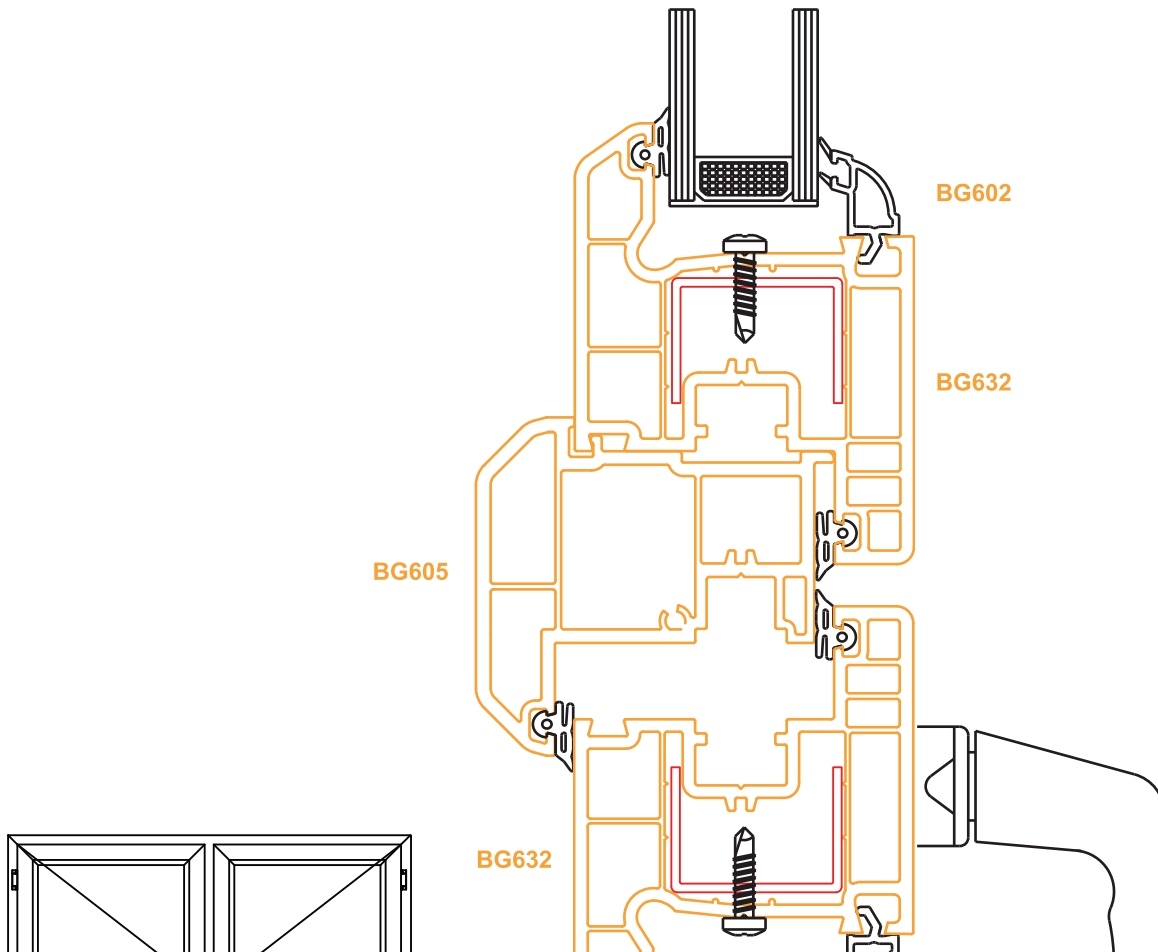

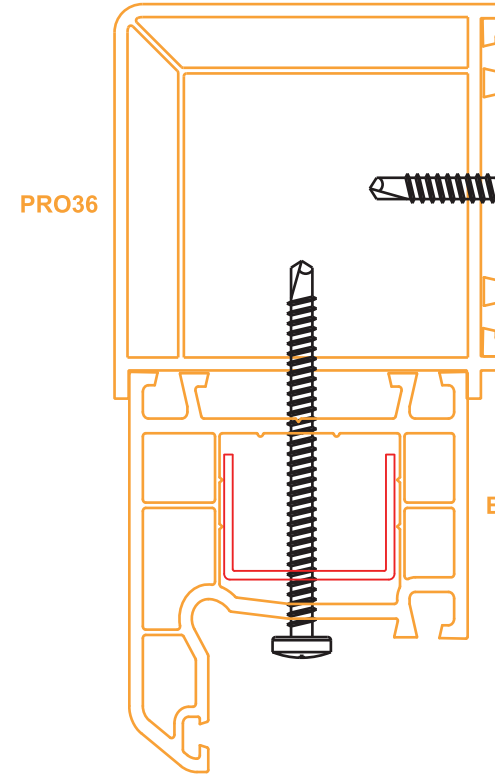
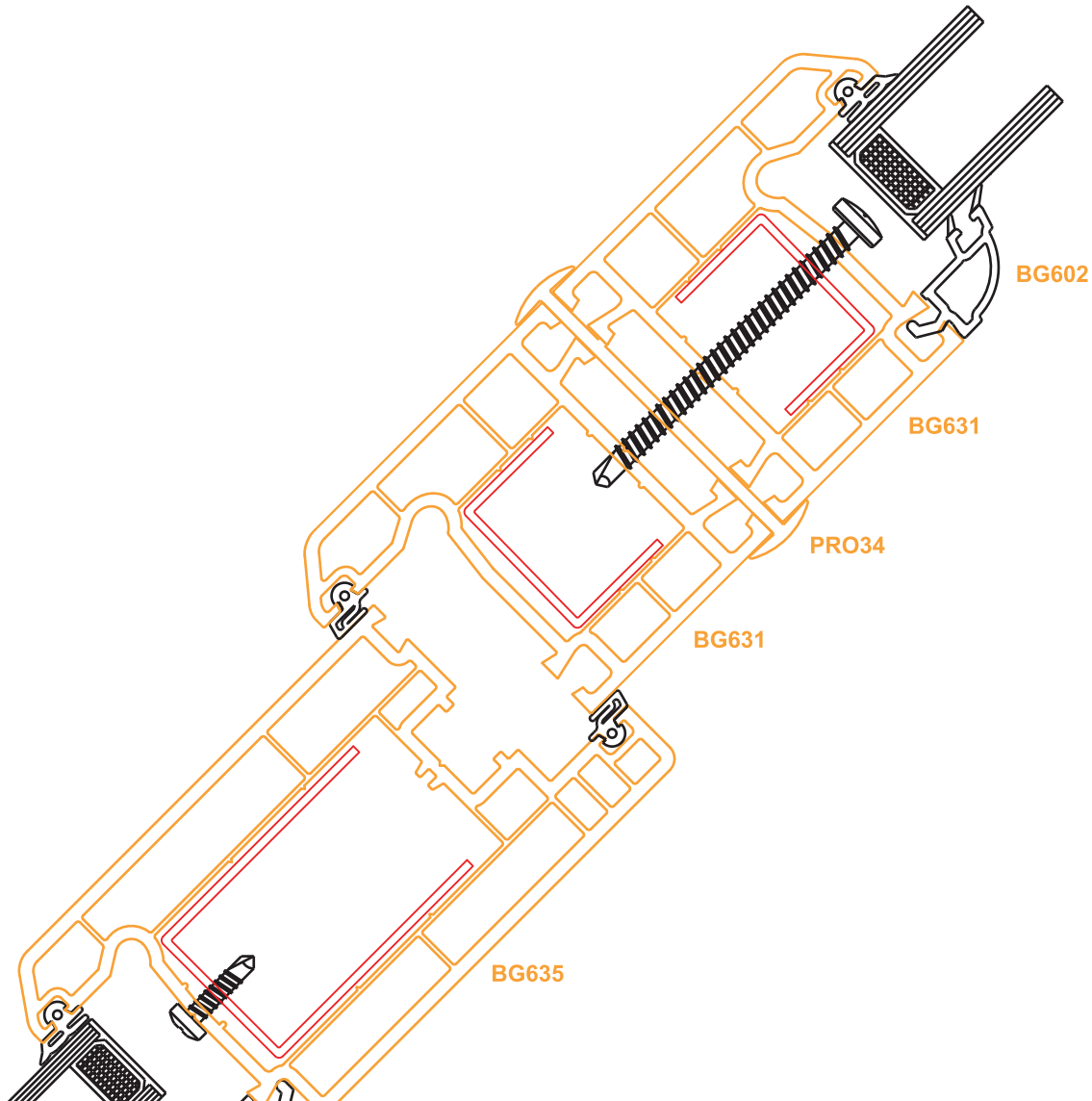

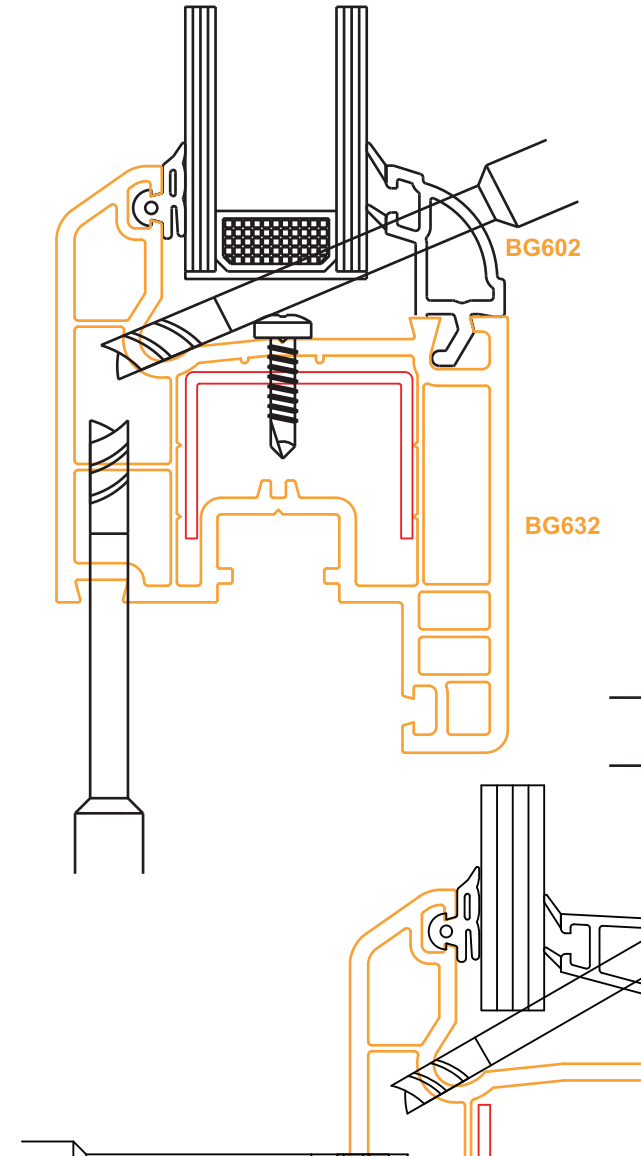
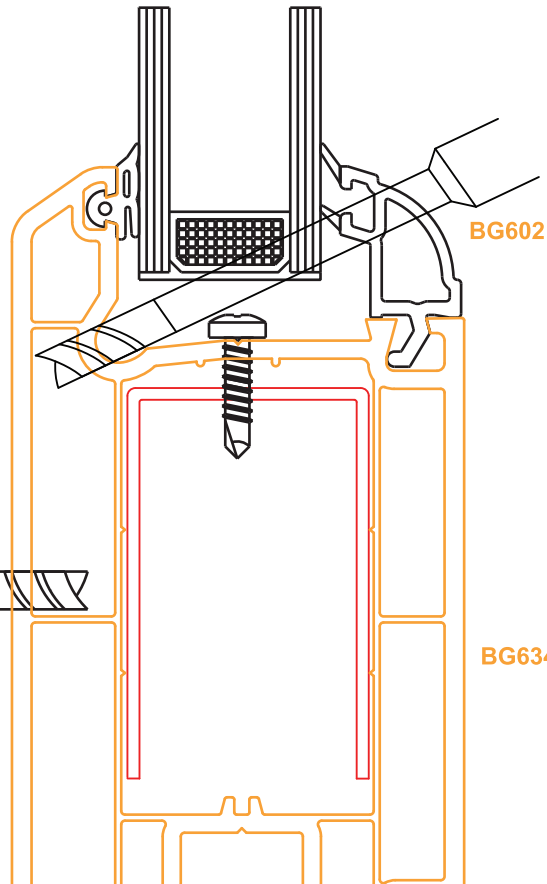
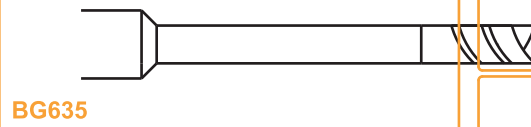
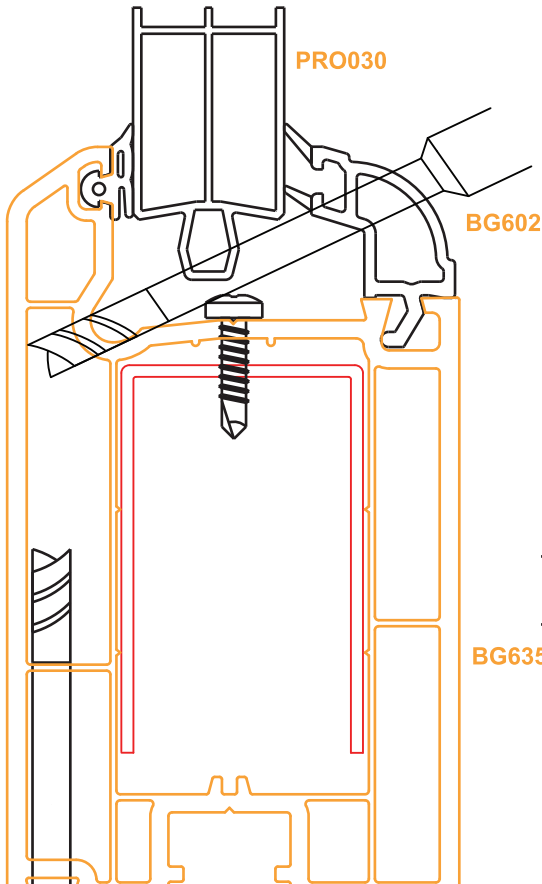



Otto Richter

BG 64

BG 64

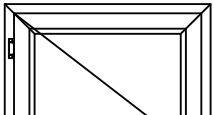
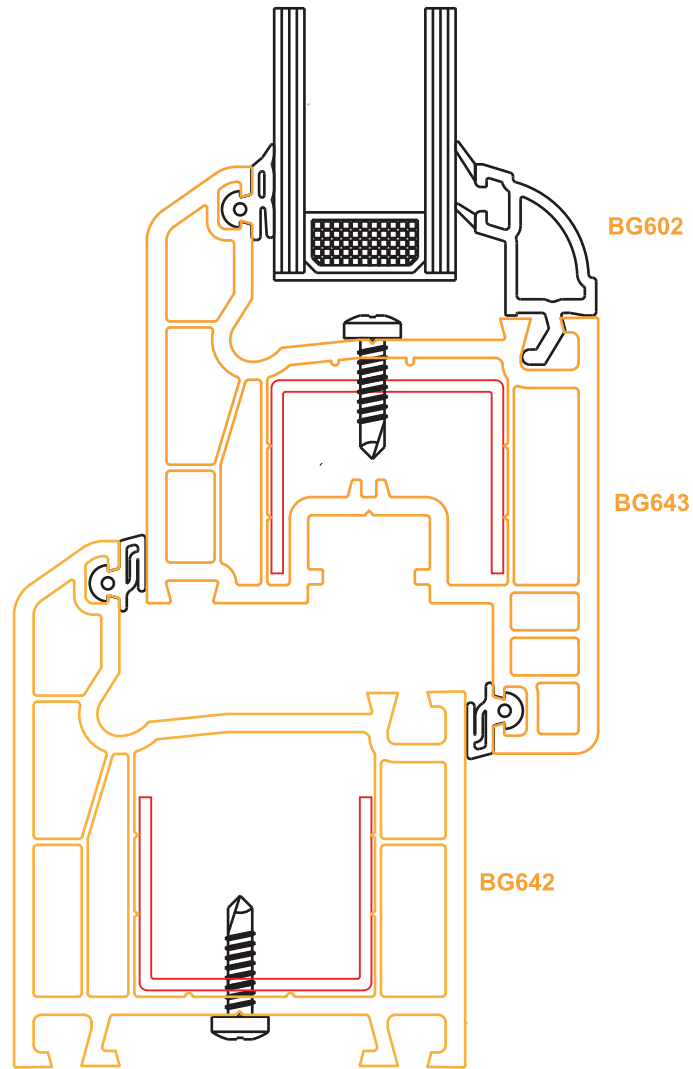

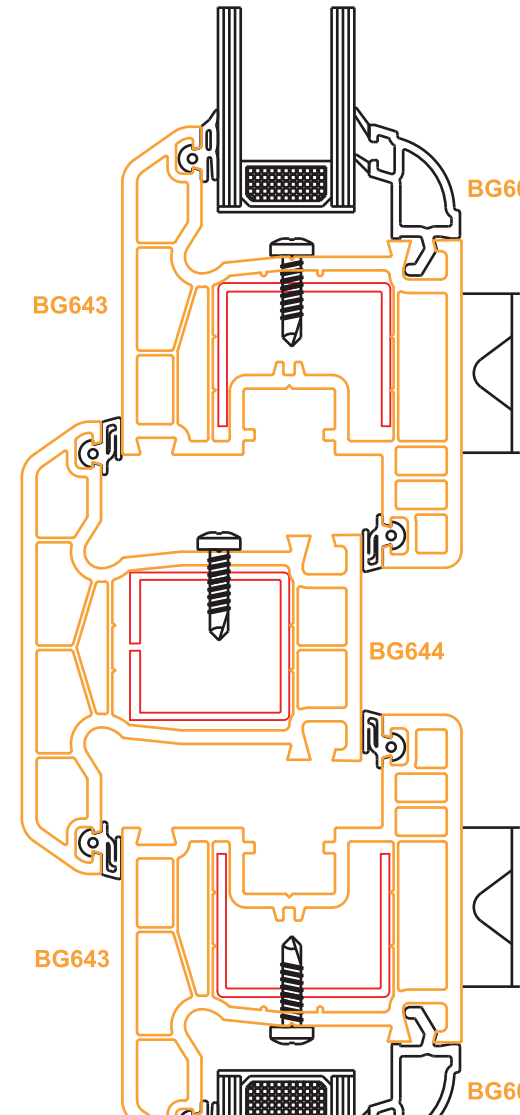
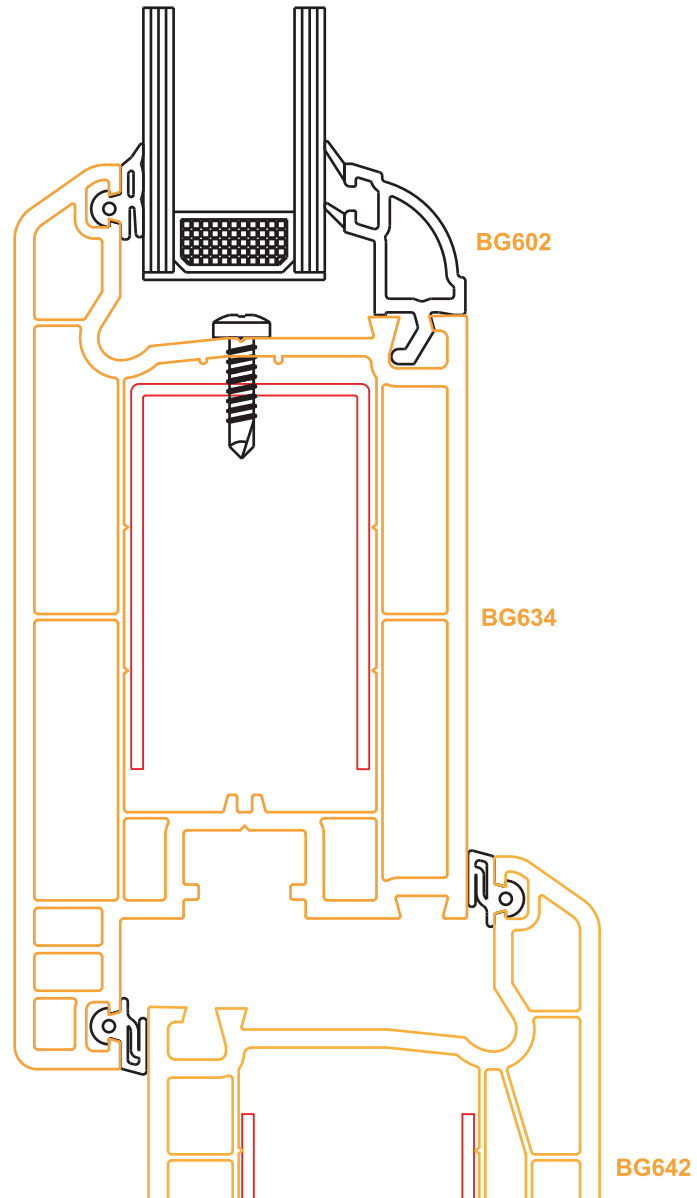
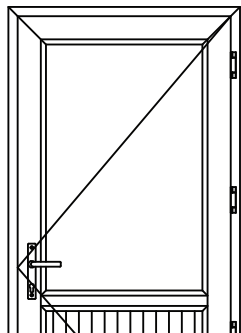



Otto Richter

BG 64

BG 64

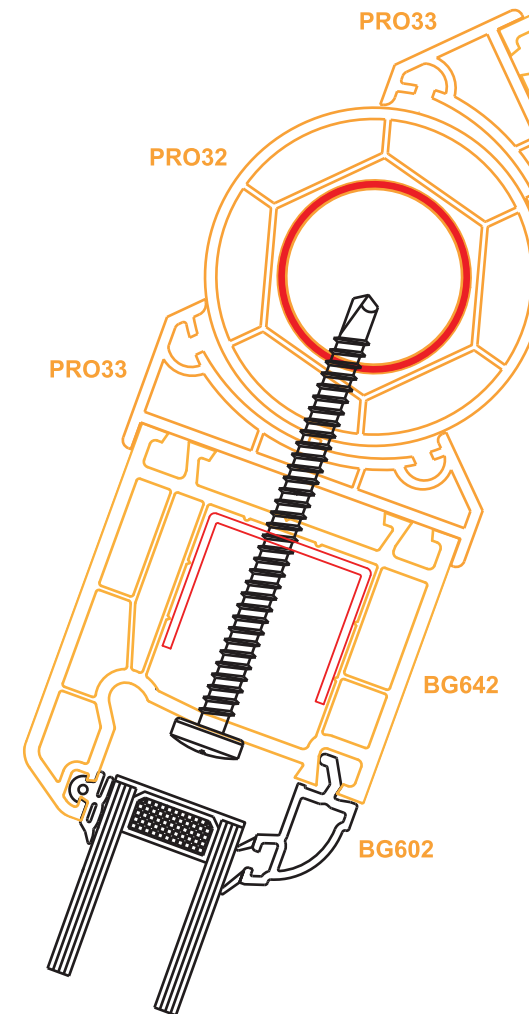
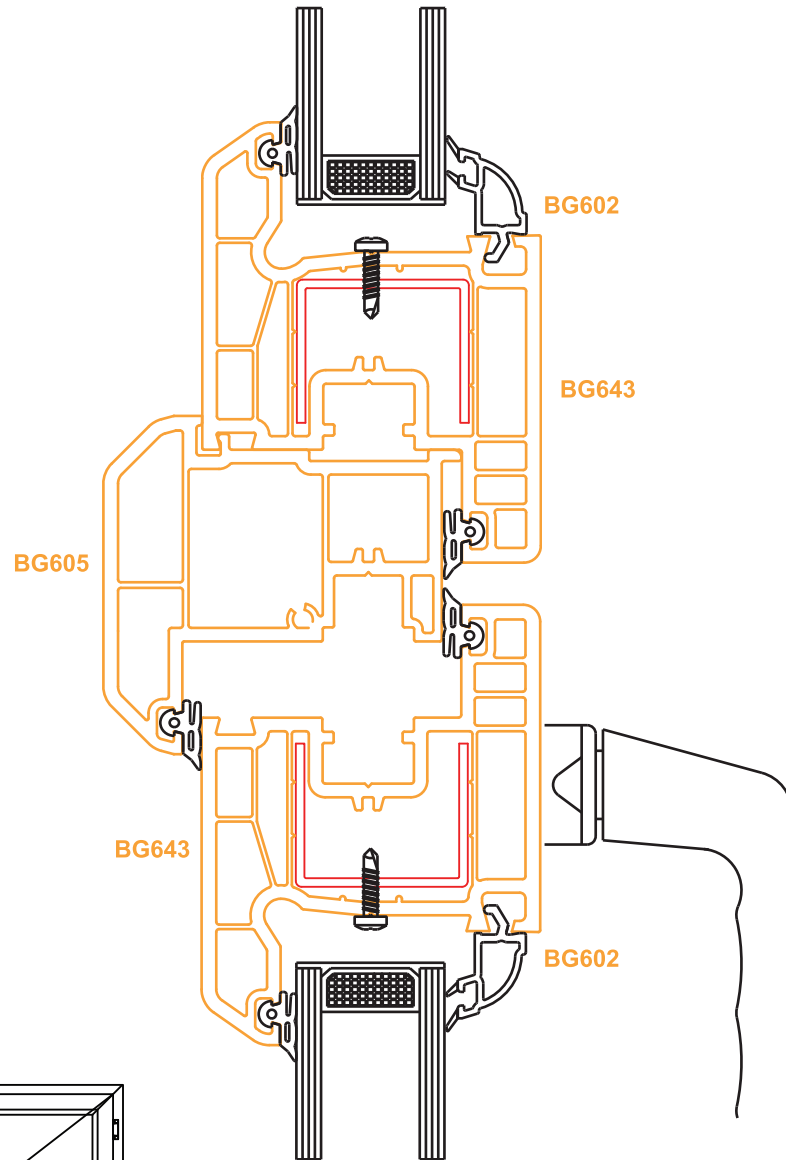

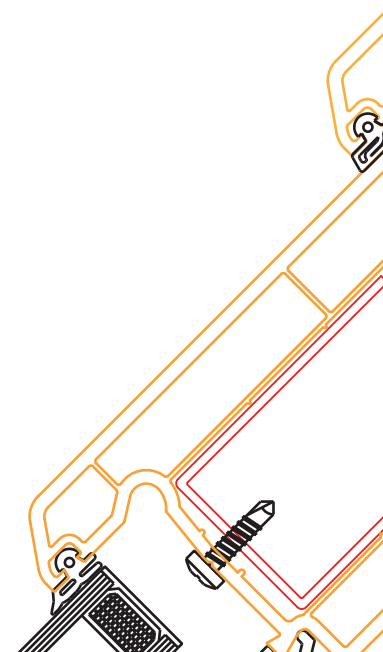
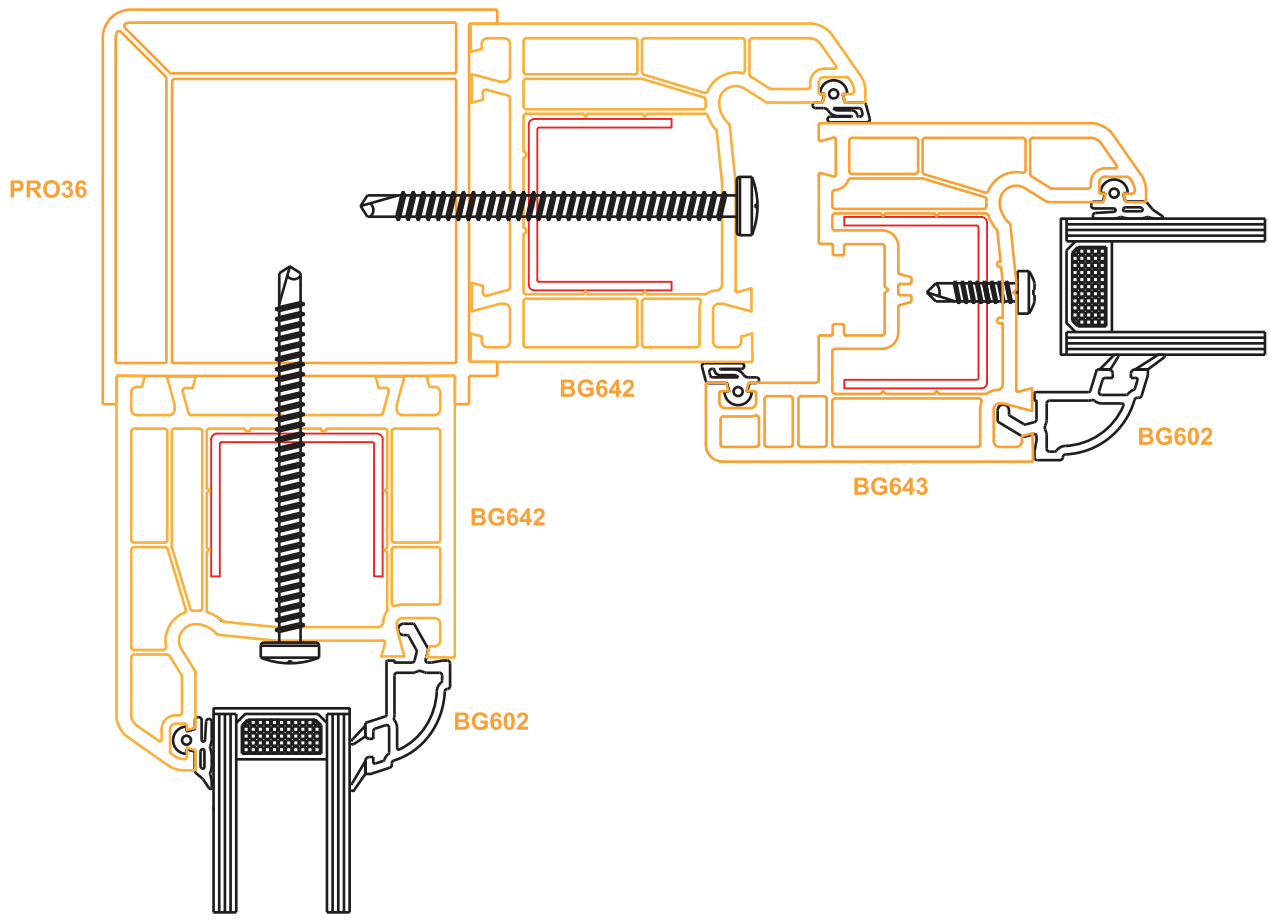

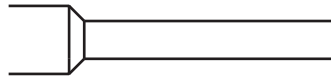
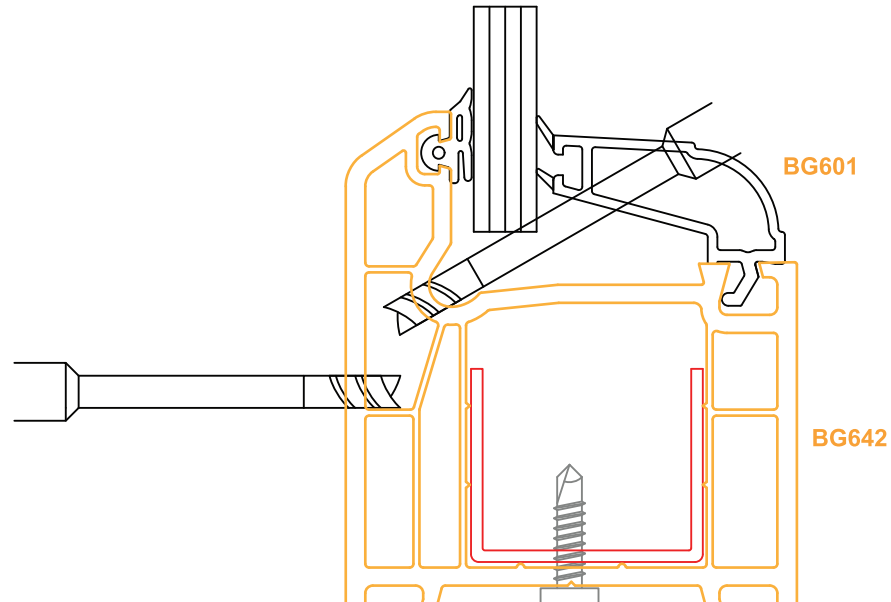
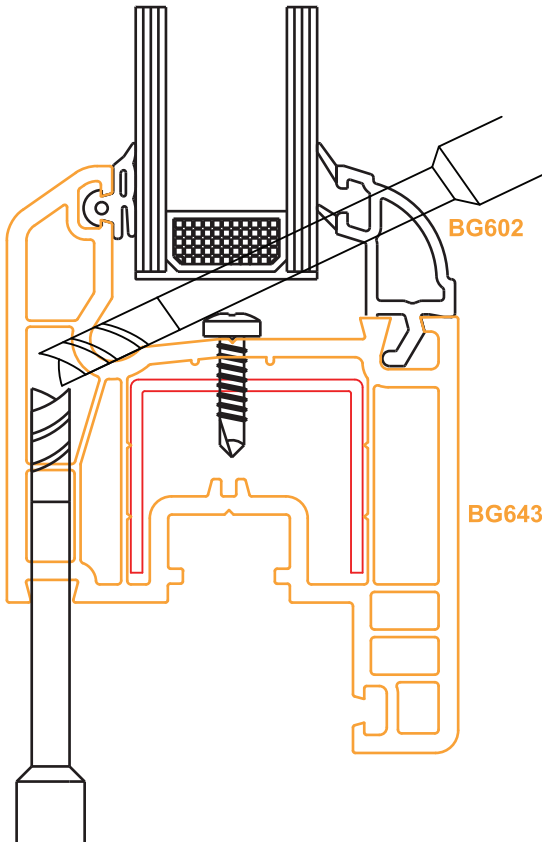



Otto Richter

BG 631

BG 633

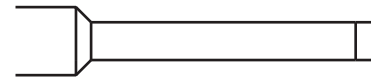
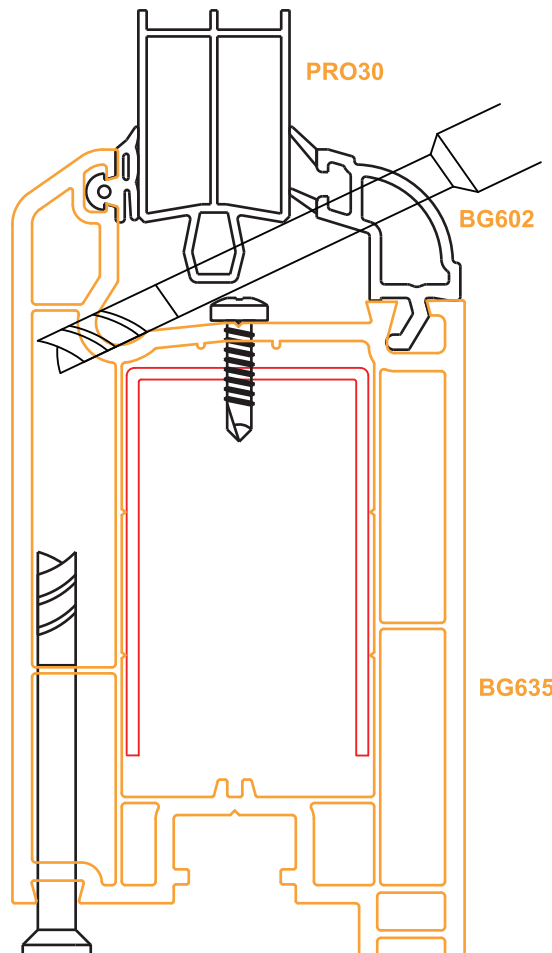

BG634

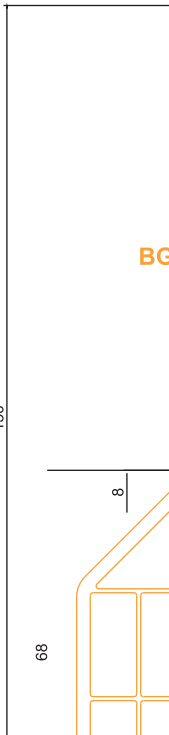
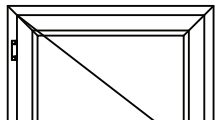
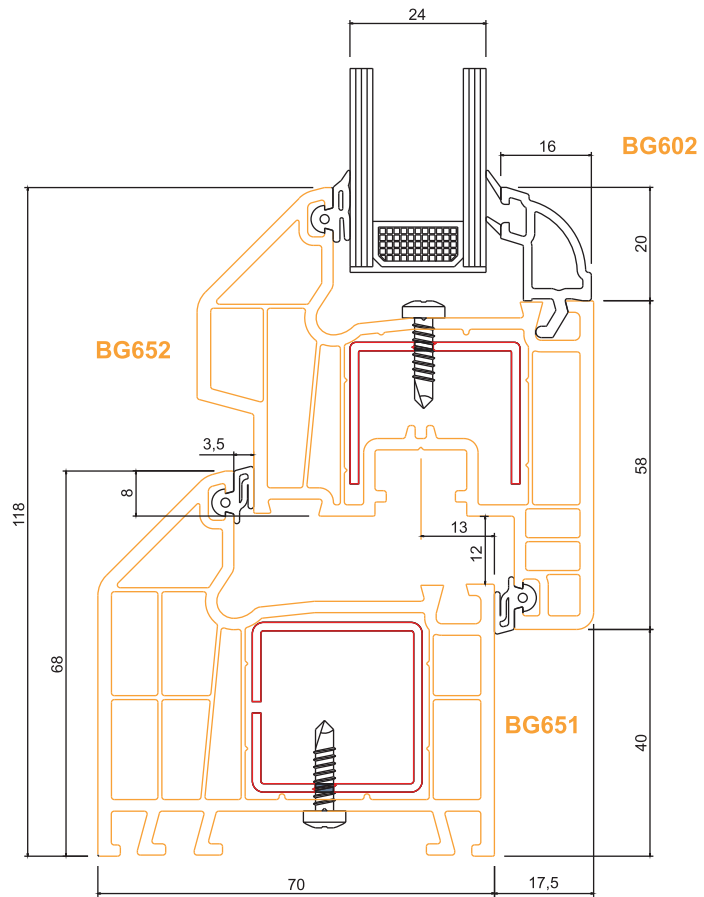



BG 65

BG 65

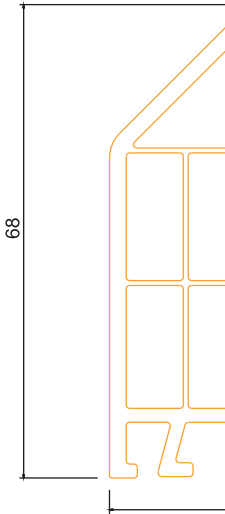
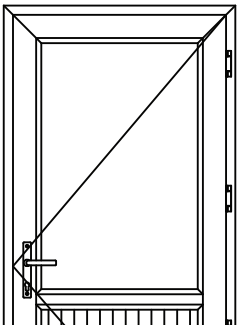
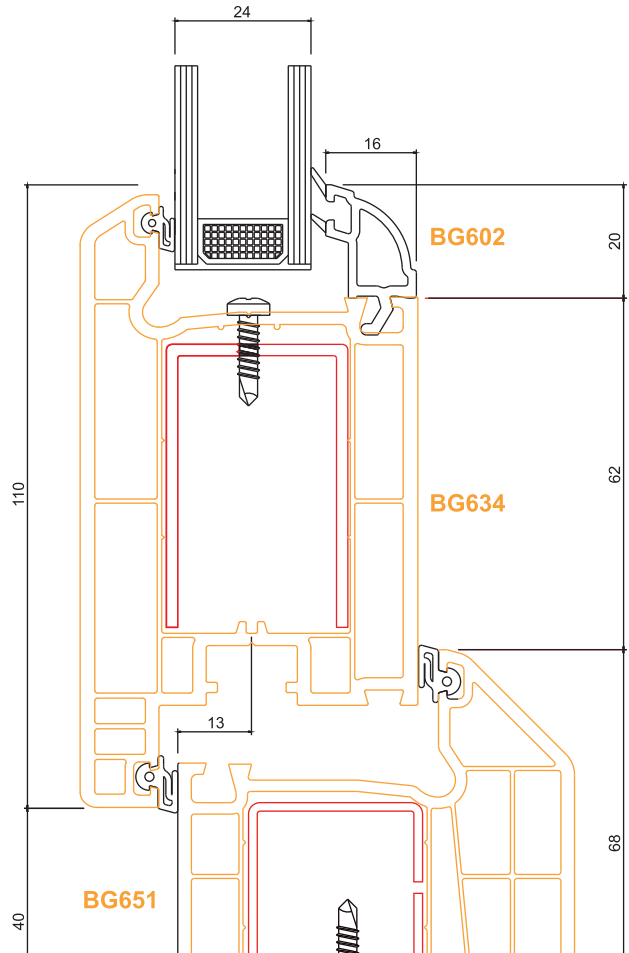

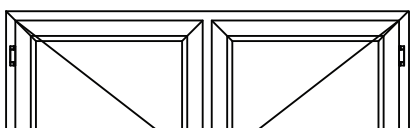
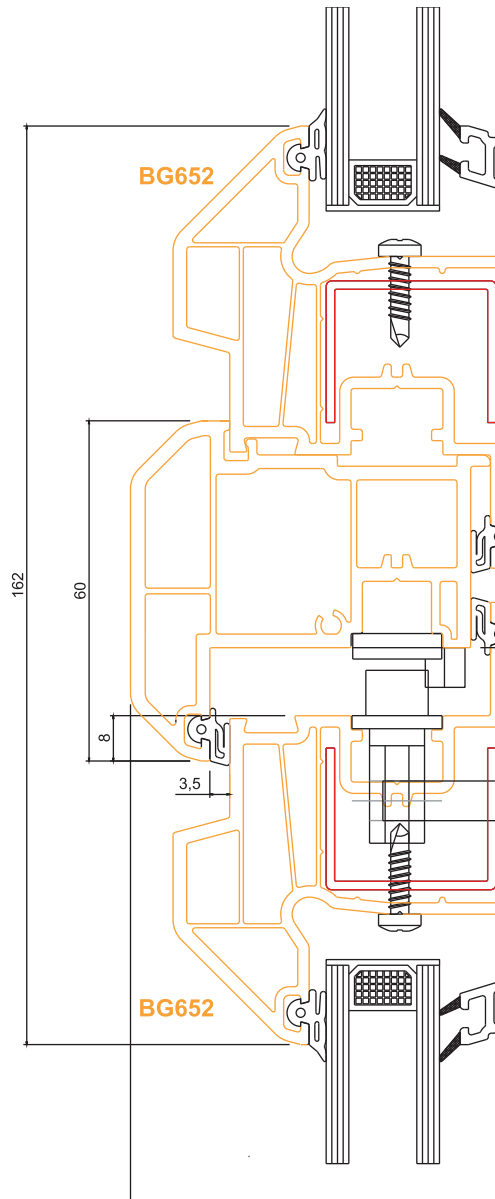
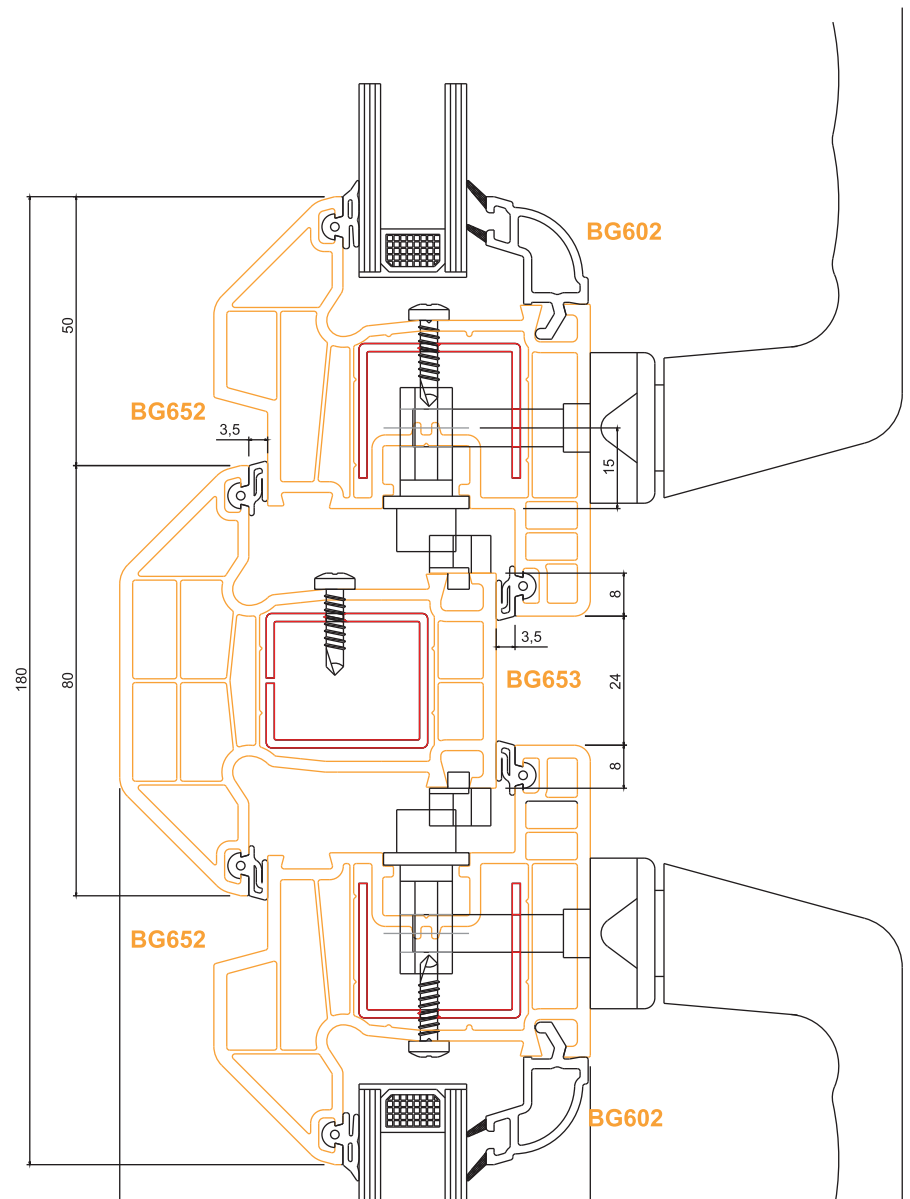

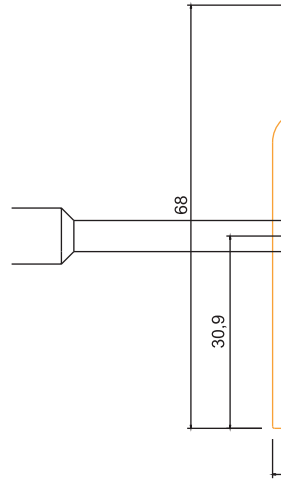
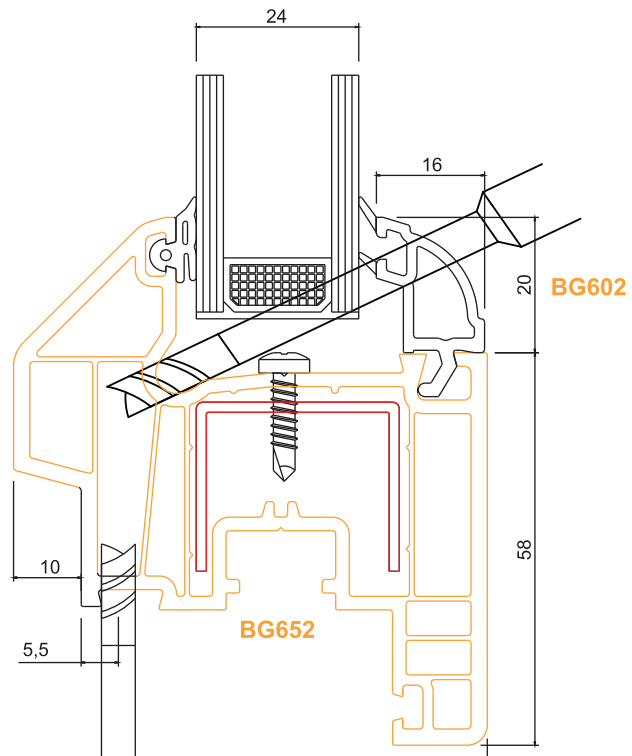
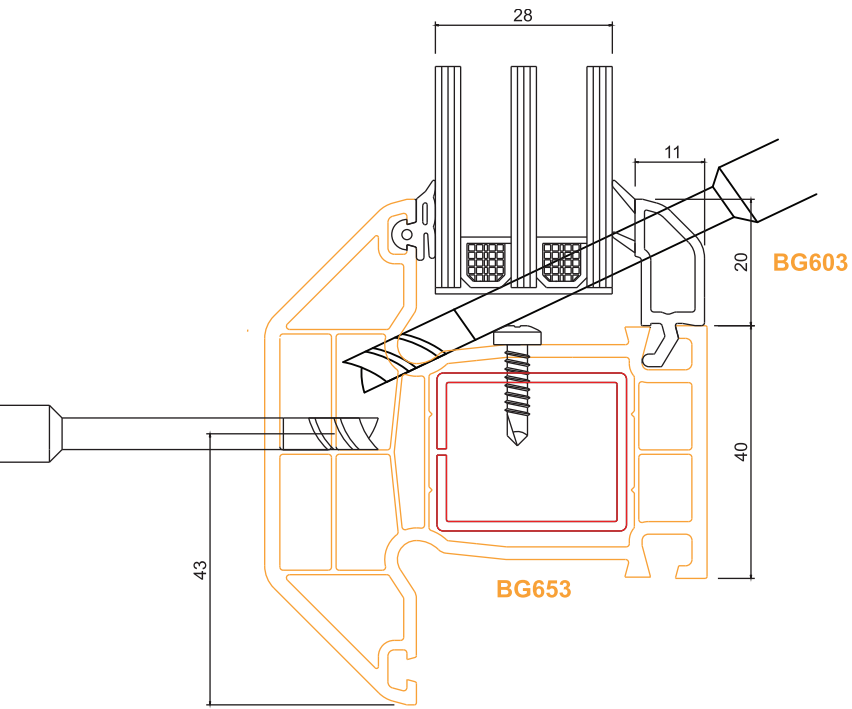

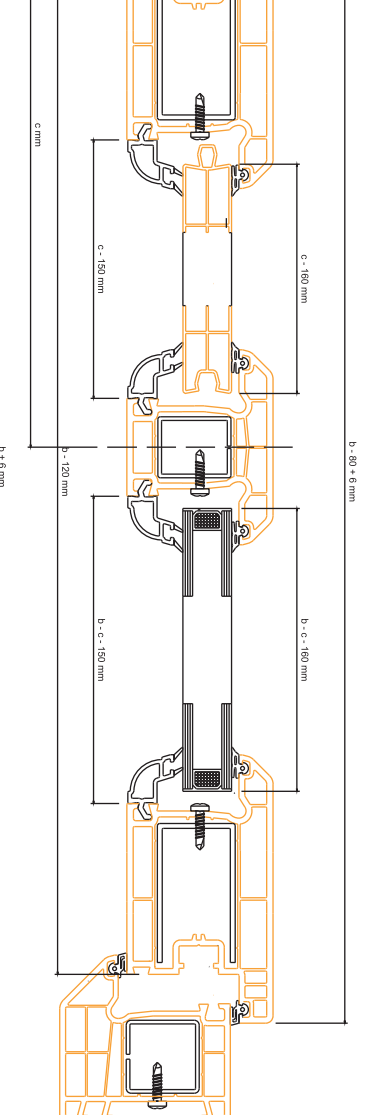
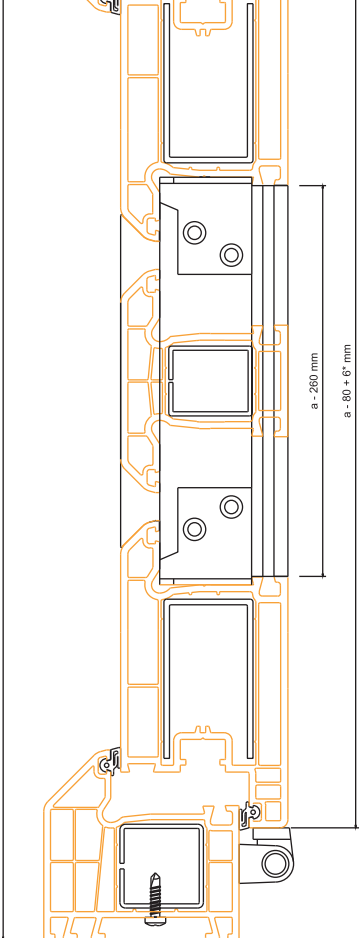
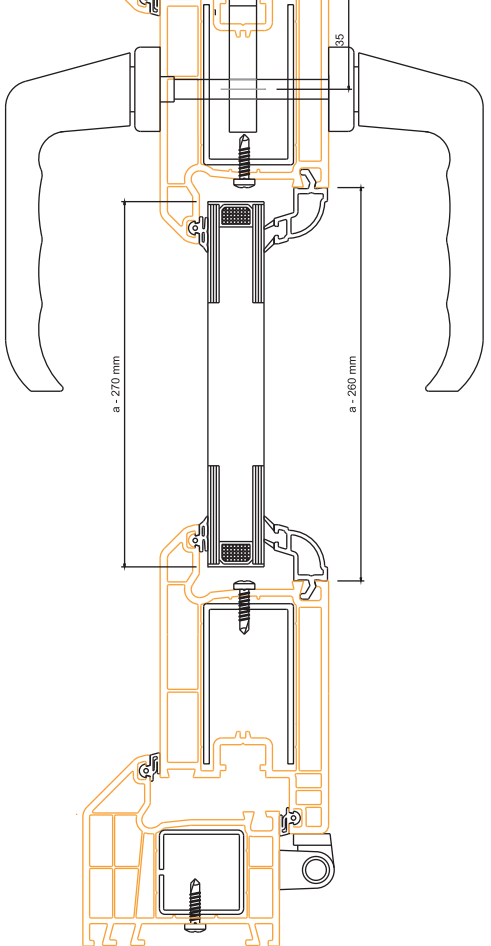
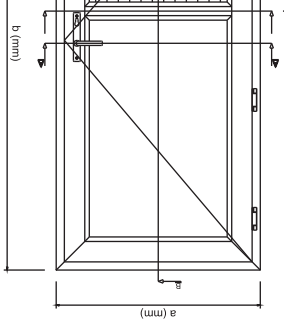

BG 65

BG 65

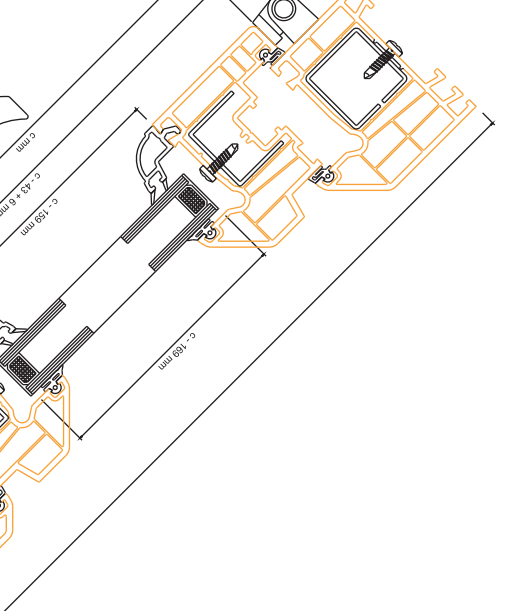
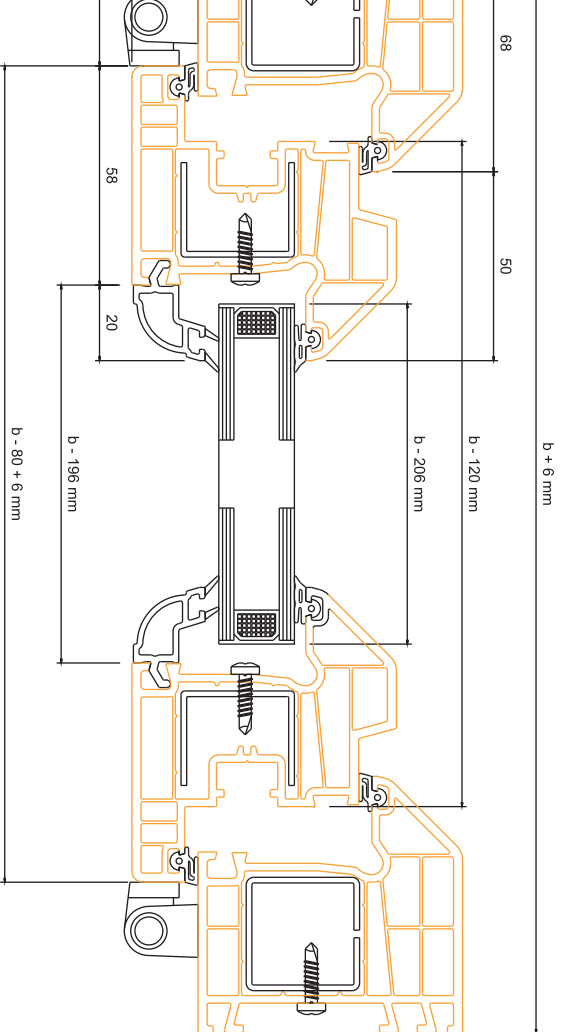
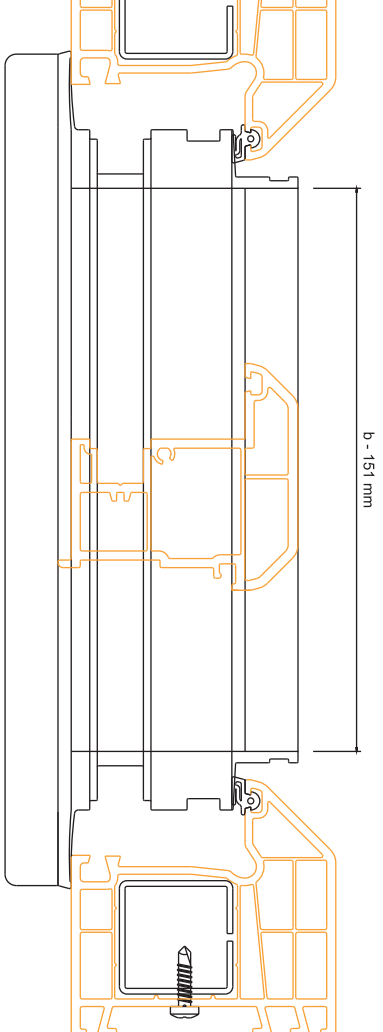

BG 65

BG 65

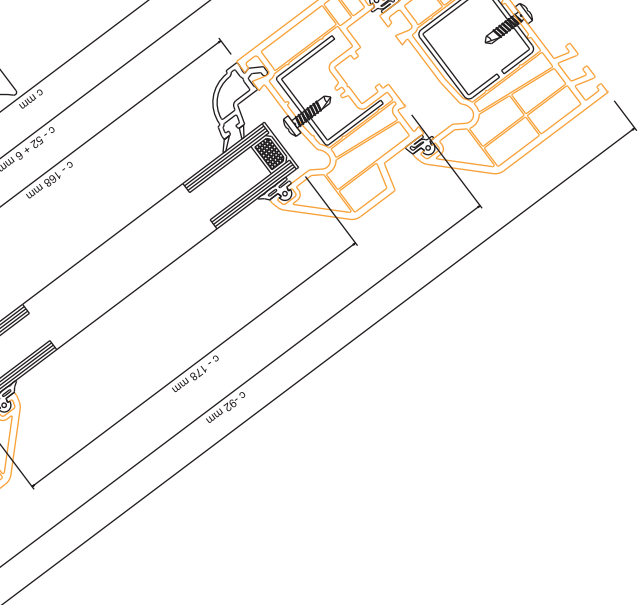
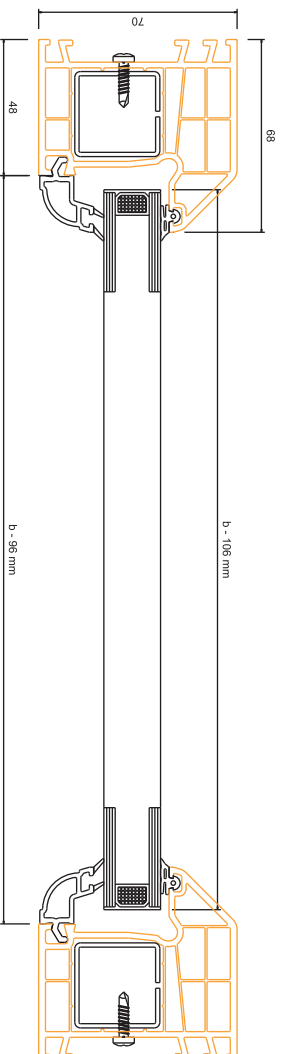
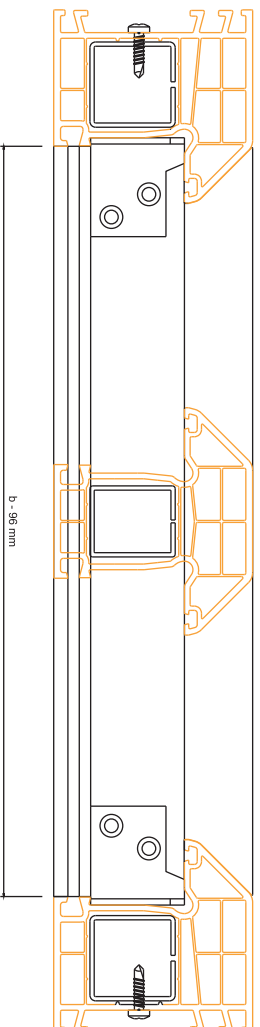
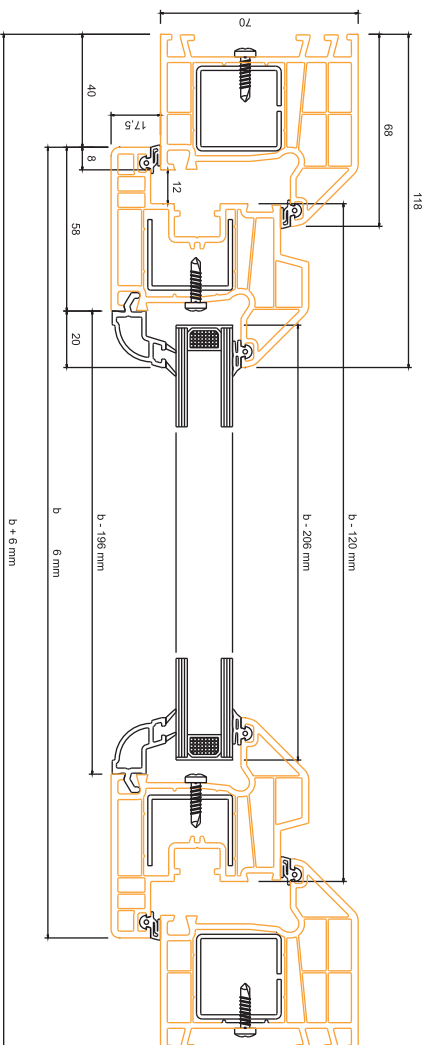

BG 65

BG 65

